

GI FibreMDU

Optical Output LNB



- Converts all 4 Universal IF bands to a single optical output (H/H - H/L - V/H - V/L = Single Optical Output)
- Capable of supplying all converted signals to 32 distribution points spread over a 10 kilometre radius
- 40mm Feed Horn or C120 Flange versions available

The **GI FibreMDU** Optical Output LNB radically changes how satellite IF signals are dealt with compared with conventional Universal LNBs.

This innovative new design uses patented technology to frequency stack both horizontal and vertical polarities, creating a single IF frequency range of 950MHz - 5.45GHz. The newly created single band is then frequency modulated optically and output using a 1310nm laser internal to the Optical Output LNB.

Powered separately the Optical LNB takes the required <450mA from a standard 12v supply utilising a standard female F type connector.

Fibre connection is made via a standard FC/PC connector feeding the passive distribution network on single mode fibre optic cable.

With an optical output of +/- 6.5 dBm the **GI FibreMDU** Optical Output LNB is easily capable of driving up to 32 **GI FibreMDU** converters (see **GI FibreMDU** specification sheet) located within a 10km radius.

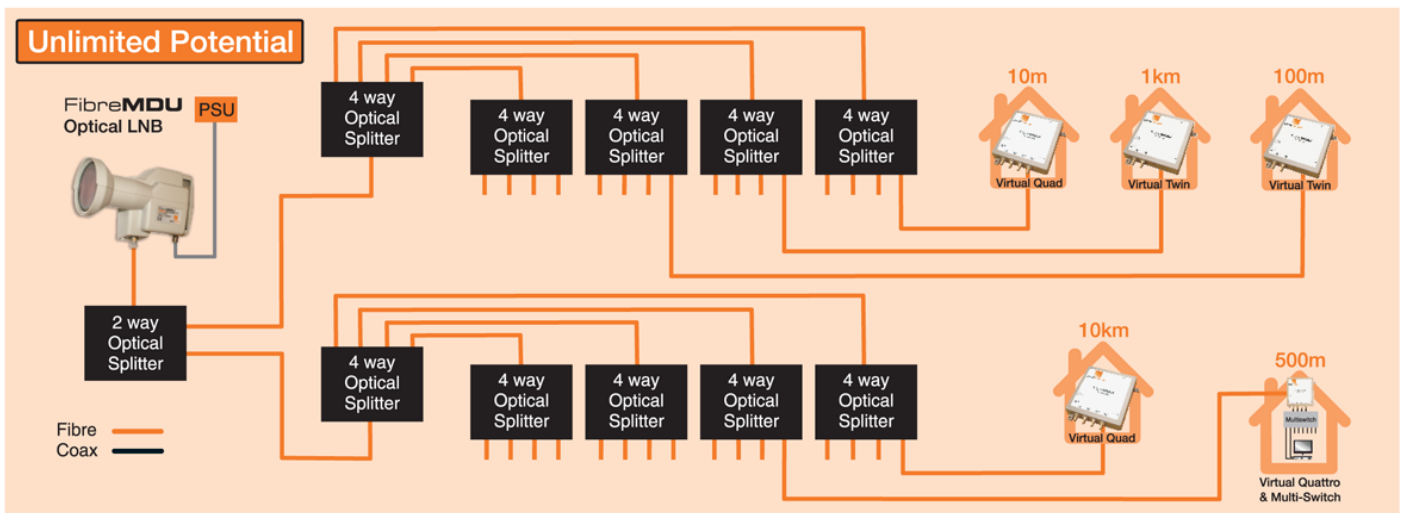

GI FibreMDU

Optical Output LNB

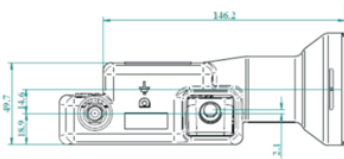

O-LNB

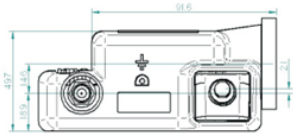
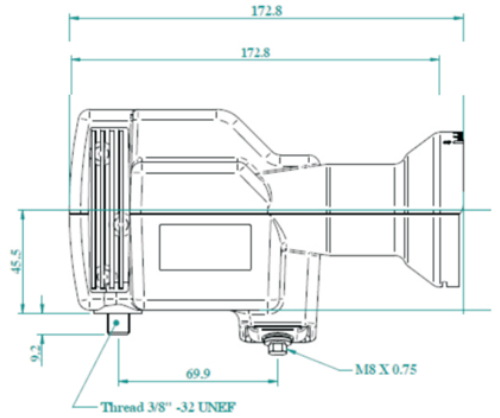
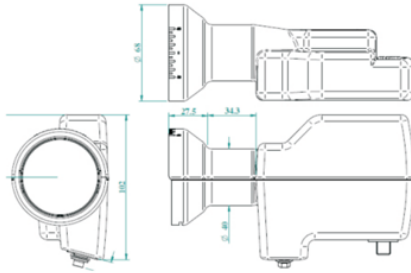

O-LNB C120

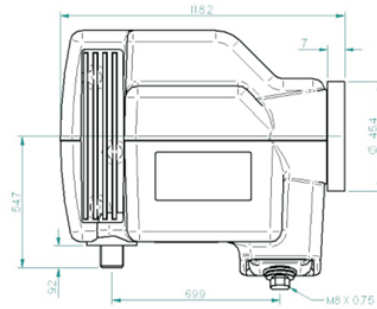
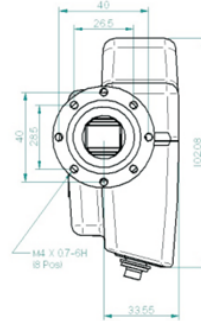

Specification

INPUT FREQUENCY

The input RF range is 10.7-12.75GHz linearly polarised (horizontal and vertical).

OUTPUT FREQUENCY

950 MHz - 5.45 GHz. The modulated laser output will be at 1310nm.

OPTICAL OUTPUT POWER

7dBm nominal at 25°C, ± 2dBm over full temperature range.

NOISE FIGURE

Typical at 25°C	Max at 25°C	Typ Over Temperature	Max Over Temperature
0.5dB	1.1dB	0.7dB	1.3dB

GAIN

Max gain: 72 dB, Min Gain: 62 dB, at room temperature.
Gain variation over temperature (-30° to + 60°C): +/- 2dB
Gain flatness (0.95 to 5.45 GHz): 5 dB per band

GAIN RIPPLE

The gain ripple per 26MHz bandwidth must be less than ±0.5dB.

PHASE NOISE

Offset Frequency	Maximum Limit
1KHz	-55dBc/Hz
10KHz	-80dBc/Hz
100KHz	-100dBc/Hz
1MHz	-110dBc/Hz

LOCAL OSCILLATOR STABILITY

Condition	Maximum Variation from Nominal Frequency
Initial Setting	±1 MHz
Temp. Drift (-40° to +60°C)	±2 MHz
Aging and Total Drift (10 Year Life)	±4 MHz

CURRENT CONSUMPTION

Current consumption < 450 mA.

IMAGE REJECTION

40dB min.

CROSS POLAR ISOLATION

Typically 30dB, Minimum 25dB

OUTPUT CONNECTORS

DC Input	Female F-Type
Optical Output	FC/PC

SUPPLY VOLTAGE

Condition	Limit
Nominal Supply Voltage	12 V

SPURIOUS OUTPUT

(after recovering modulation)
In band (950MHz-3GHz, 3.4GHz-5.45GHz) : -25 dBc

MECHANICAL AND ENVIRONMENTAL

TEMPERATURE RANGES

Condition	Limits
Ambient Operating Temperature Range	-30°C to +60°C
Storage Temperature Range	-40°C to +70°C

DISH AND LNB MECHANICAL INTERFACE

The LNB will be attached to the satellite dish using a 40mm clamp. The recommended fitting for the C120 version is the ADF-120 Adjustable Feed Horn.